



**Algas-SDI**<sup>TM</sup>

*...Innovative liquid vaporizing and gas mixing solutions*

---

**ISO 9001**  
Certified

**ZIMMER**<sup>TM</sup>

***Electric Vaporizer***

***Operations & Maintenance  
Manual***

151 S. Michigan Street, Seattle, Washington, USA 98108  
Tel: 206-789-5410 Fax: 206-789-5414 Web: [www.algas-sdi.com](http://www.algas-sdi.com)

# **DISCLAIMER and COPYRIGHT**

## **DISCLAIMER**

---

Read this Operations and Maintenance Manual before operating the **ZIMMER™**!

Algas-SDI International, LLC shall not be liable for technical and/or editorial errors or omissions in this manual. Algas-SDI makes no warranties, express or implied, including the implied warranties of merchantability and fitness for a particular purpose with respect to this manual. In no event shall Algas-SDI be liable for any special or consequential damages including, but not limited to, loss of production time or loss of profits.

Product names used in this manual are for the manufacturer or supplier identification only and may be trademarks, or registered trademarks, of these companies.

In accordance with the manufacturer's policy of continual product improvement, Algas-SDI reserves the right to use alternate manufacturer's components as vendor availability dictates. For further information please contact Algas-SDI.

## **COPYRIGHT**

---

Copyright 2010 by Algas-SDI International, LLC  
Seattle, Washington, USA 98108

All rights reserved. No part of this manual may be reproduced or copied in any form or by any means, photographic, electronic, or mechanical without the prior express written consent from Algas-SDI International, LLC.

# **WARRANTY and CONTACT INFORMATION**

## **WARRANTY REGISTRATION**

Fill out the Warranty Registration information on the last page of this manual. Refer to the nameplate on the unit to fill out the product registration. Then make a photocopy and mail to the address shown at the bottom.

## **WARRANTY**

Algas-SDI International, LLC (ASDI) warrants that the equipment is free from defects in materials and workmanship under normal use and service. ASDI agrees to repair or replace, at its option, without charge F.O.B. factory, any part which has proven defective to the satisfaction of ASDI within one (1) year from the date of the original installation or with 18 months from the date of shipment, whichever is earlier. Equipment, which in the opinion of ASDI, has been damaged in shipment or by improper installation or operation, or has been abused or tampered with in any way, will not be accepted for return under warranty.

ASDI will not accept back charges for work performed by others upon or in conjunction with ASDI equipment, unless prior authorization is given by means of an ASDI purchase order. ASDI will not be liable by reason of shutdown, non-operation or increased expense of operation of other equipment, or any other loss or damage of any nature, whether direct or consequential, arising from any cause whatsoever.

ASDI makes NO other warranty of any kind, whatsoever expressed or implied; and all warranties of merchantability and fitness for a particular purpose are hereby disclaimed by ASDI and excluded from these terms of sale. No person has any authority to bind ASDI to any representation or warranty other than this warranty.

## **ASDI CONTACT INFORMATION**

If you have questions or need help with your equipment, or want information on other products, contact your distributor or *Algas-SDI* at:

**Telephone: 1.206.789.5410**

**Facsimile: 1.206.789.5414**

**E-mail: [sales@algas-sdi.com](mailto:sales@algas-sdi.com)**

**Internet: [www.algas-sdi.com](http://www.algas-sdi.com)**

# **TECHNICAL SPECIFICATIONS**

		<b>Capacity, kg/hr (gal/hr)</b>		
		<b>LPG</b>	<b>Propane</b>	<b>50/50 LPG</b>
<b>Model</b>	<b>Z40L</b>	40 (20)		
	<b>Z40P</b>		40 (20)	
	<b>Z40S</b>			40 (20)

<b>Model</b>	<b>Kg/Hr</b>	<b>GPH</b>	<b>kW</b>
<b>Z50</b>	50	25	5.72
<b>Z40</b>	40	20	5.28
<b>Z26</b>	26	13	3.41
<b>Z20</b>	20	10	2.64
<b>Z17</b>	17	8.5	2.27
<b>Z14</b>	14	7	1.89

**Pressure Relief Valve Set point:** 17,24 bar (250 psig)

**Heat Exchanger:**  
**MAWP:** 17,24 bar @ 343°C (250 psi @ 650°F)  
**MDMT:** -29°C @ 17, 24 bar (-20°F @ 250 psi)  
**Hydrostatic Test Pressure:** 25.86 bar (g) (375 psig)

**PED:** SEP (Sound Engineering Practice)

**Electrical:**  
**Voltage:** 100 - 240VAC  
**Phase:** 1  
**Frequency:** 50/60Hz  
**Amps:** 32, 7 Amps (100V) – 19,5 Amps (240V)  
**Kilowatts:** 3,27 - 4,68 kW  
**Load type:** Inductive

**Circuit breaker:**

**Z40** - 208-240V use a UL listed 30 amp high inrush circuit breaker  
 100-120V use a UL listed 40 amp high inrush circuit breaker  
**Z50** – 208-240V use a UL listed 40 amp high inrush circuit breaker  
 100-120V use a UL listed 50 amp high inrush circuit breaker

**Hazardous Area Rating:**

**CE** 0575 **Ex** II 2 G  
**DEMKO 03 ATEX 0215525**  
**EEx d IIA T4**

**UL** US LISTED  
 LPG VAPORIZER  
 FOR HAZARDOUS  
 LOCATIONS 2PA5  
**Class I, Division 1, Group D, T4**

**Enclosure Rating:** Type 4

**Quality System:** ISO 9001  
 Lloyd's Quality Register, Certificate Number: 108266

## EC Declaration of Conformity

**WE,** Algas-SDI  
 151 South Michigan Street  
 Seattle, WA 98108 USA

**Declare, solely under own responsibility, that the product**  
 Model: Zimmer Series, LPG vaporizer for converting liquefied petroleum to  
 vapor by means of and electric heater/heat exchanger.

**Mentioned in this declaration, complies with the following standards and/or  
 normative documents:**

Requirements	Remarks	Certificates No.
94/9/EC, Annex VII	Product Quality Assurance ATEX Directive	DNV-2006-OSL-ATEX-0166Q
<b>Notified Body:</b>	Det Norske Veritas AS Veritasveien 1 N-1322 Hovik, Norway	0575
	CE  II 2 G EEx d IIA T4	DEMKO 03 ATEX 0215525
EN 50014: June 1997 February 1999 February 1999	Electrical Apparatus for Potentially Explosive Atmospheres – General Requirements Amendment 1 Amendment 2	
EN 50018: November 2000 September 2002	Electrical Apparatus for Explosive Gas Atmospheres – Flame proof Enclosures “d” Amendment 1	
<b>Type Examination Body:</b>	UL International DEMKO A/S P.O. Box 514 Lyskaer 8 DK-2730 Herlev, Denmark	0539
97/23/EC	Pressure Equipment Directive Sound Engineering Practice	SEP

Technical Standards Applied: ASME B&PV Code, Section VIII, Div. 1



Mike Zimmer, PE  
 Directory of Engineering  
 June 20, 2009



# **TABLE of CONTENTS**

<b><u>1. INTRODUCTION</u></b>	<b>9</b>
Description/Overview	9
How the Vaporizer Works	9
Basic Features	10
Model Selection	10
Propane version (Z40P)	11
Propane version (Z40P) – Table 1	11
LPG version (Z40L)	11
LPG version (Z40L) – Table 2	11
50/50 version (Z40S)	12
50/50 version (Z40S) – Table 3	12
Available Options	13
Safety	14
<b><u>2. INSTALLATION</u></b>	<b>15</b>
Preparing the Site	16
Materials you may need for Installation	17
Mounting the <b>ZIMMER™</b>	20
<b>ZIMMER™</b> Tank Mounting Kit Instructions	21
Piping	25
Installing Multiple Units	28
Common Piping Problems	29
Electrical Service	29
<b><u>3. OPERATION</u></b>	<b>31</b>
Putting Your Vaporizer into Service	31
Shutting Down the System	32
<b><u>4. MAINTENANCE</u></b>	<b>33</b>
Servicing your <b>ZIMMER™</b>	33
Drip leg and Filter	33
Inlet valve (Cleaning Instructions)	33
Heating System	35
Relief valve	35

<b><u>5. TROUBLESHOOTING</u></b>	<b>37</b>
Possible problems	<b>37</b>
Inlet valve does not open – Tree #1	<b>37</b>
Inlet valve closes during operation – Tree #2	<b>38</b>
<b><u>6. REPLACEMENT PARTS</u></b>	<b>39</b>
<b><u>7. FREQUENTLY ASKED QUESTIONS</u></b>	<b>40</b>
<b>ZIMMER™</b> Current and Power Charts	<b>42</b>

Warranty Registration - Refer to the nameplate on the unit to fill out the product registration. Then photocopy and mail to address shown.

## **REVISION HISTORY**

- April 1, 2009, Revised Tables 1
- March 16, 2009, Added Tables 1 to 3, Added Zimmer Model Z40S information and replacement parts, update assembly parts for P/N 80888
- August 25th, 2010, Revised Typical Installation with Stationary Cylinder drawing
- September 1<sup>st</sup> 2010, Added Model Z50



# ***INTRODUCTION***

# ***1***

## ***Description / Overview***

Your new **ZIMMER™** is a dry electric LPG or Propane vaporizer that adds energy to vaporize liquid fuel when the amount of energy available from the natural environment is insufficient for vaporization. A primary benefit of this device is that it allows greater capacities from smaller amounts of stored LPG. Often time's code restrictions limit the number and size of cylinders that can be stored next to a building or in a small space. The **ZIMMER™** overcomes this problem and allows loads up to 80 kg/hr (40 gal/hr), or more, with two units in parallel and can be supplied by as few as one cylinder or tank of any size, or as many as can be manifolded together according to local codes.

All **ZIMMER™** vaporizers are manufactured under a certified ISO 9001 quality system. The inlet control valve and heat exchanger have been proof tested to 172 bar (2500 psig).

## ***How the Vaporizer Works***

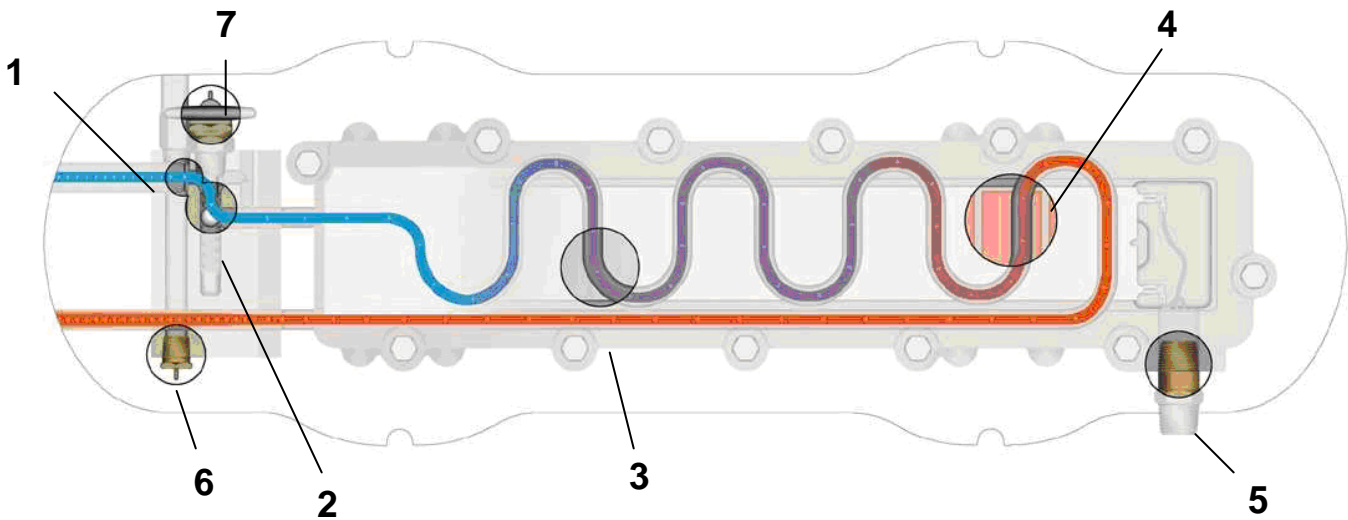

**Ref. 1** – Liquid LPG enters the inlet valve manifold where the inlet valve screen prevents debris from entering.

**Ref. 2** – Liquid flows through the inlet valve where it is controlled by a metal-to-metal seat and ball. The infinite seating positions of the ball provide long life, while the inverted seat prevents foreign material from collecting on the valve seat.

**Ref. 3** – As liquid passes through the tubes energy is transferred, causing the liquid to boil. Steel tubes cast into the aluminum heat sink provide a secure pressure boundary and exceptional heat transfer.

**Ref. 4** – Energy drawn from the heat sink is replenished by replaceable self-regulating heaters without the need for switches, temperature sensors, relays, or other controls. The heaters cannot overheat by nature of their design and they consume only as much energy as is needed for vaporization.

**Ref. 5** – Power is supplied to the heaters by a wide range of voltages through a factory-mounted explosion-proof seal. (Optional)

**Ref. 6** – As vapor exits the unit, it heats or cools the temperature-sensitive bulb, providing feedback to the inlet valve.

**Ref. 7** – The inlet control valve receives feedback from the temperature-sensitive bulb and combines it with pressure feedback to ensure only superheated vapor (superheat is the amount of temperature above the dew point) leaves the vaporizer. The valve modulates the inlet flow to control the process.

In the event of a power failure the unit will continue to operate until all of the available energy has been used. If the power comes back on before all of the energy has been used, the heat process being served by the LPG should remain engaged. Otherwise the inlet valve will close as the heat stored in the heat exchanger is transferred to the passing fluid. When the power comes back on the vaporizer will automatically re-energize and begin operation.

## ***Basic Features***

The heating elements are self-temperature-regulating and therefore do not have (or need) an external temperature sensor. The heat generating material of the heaters also acts as a high-temperature limit by breaking down if it reaches its critical point.

Because of its unique design features, the **ZIMMER™** can be operated on power supplies ranging from 100-240 volts AC. When operated on 110V, the maximum continuous capacity rating will be reduced by 25%.

## ***Model Selection***

The **ZIMMER™** is available in three versions –propane (Z40P), one model for LPG (Z40L) and one model for LPG (Z40S).

The difference between the Z40L, Z40P and the Z40S is in the control valve. The control valve operates on the thermodynamic properties of the specific gas (either LPG or commercial propane). The valve expects to see the vapor exit the vaporizer at 8 °C (15 °F) higher than the boiling point of the respective gas. The unique function of the valve is that it senses both pressure and temperature to truly predict the boiling point.

The valve is clearly marked with a sticker indicating that it is to be used with LPG, Propane or 50/50 (LPG).

**Propane version (Z40P) – See Table 1**

- Use with 85% or greater commercial Propane.
- **Never use propane which exceeds 15% Butane.**

Table 1 - Propane version (Z40P)

100% Butane	<b>Never use in this range</b>	0% Propane
15% Butane	<b>Full capacity</b>	85% Propane
0% Butane		100% Propane

**LPG version (Z40L) – See Table 2**

- Full capacity is based on LPG containing 60-80% Butane.
- **Never use LPG which contains more than 80% Butane.**
- Using the LPG version with LPG containing more than 40-60% Propane will decrease the capacity of the vaporizer.  
\*Especially in warmer environments.
- Contact A.S.D.I. for more details.

Table 2 - LPG version (Z40L)

100% Butane	<b>Never use in this range</b>	0% Propane
80% Butane	<b>Full capacity</b>	20% Propane
60% Butane	<b>*Reduced capacity</b>	40% Propane
40% Butane		60% Propane
0% Butane	<b>Do not use in this range</b>	100% Propane

**50/50 version (Z40S) – See Table 3**

- Full capacity is based on LPG containing 40-60% Butane.
- **Never use LPG which contains more than 60% Butane.**
- Using the 50/50 version with LPG containing more than 60% Propane will decrease the capacity of the vaporizer.  
\*Especially in warmer environments.
- Contact A.S.D.I. for more details.

Table 3 - 50/50 version (Z40S)

100% Butane	<b>Never use in this range</b>	0% Propane
60% Butane		40% Propane
40% Butane		60% Propane
0% Butane		100% Propane
	<b>Full capacity</b>	
	<b>*Reduced capacity</b>	

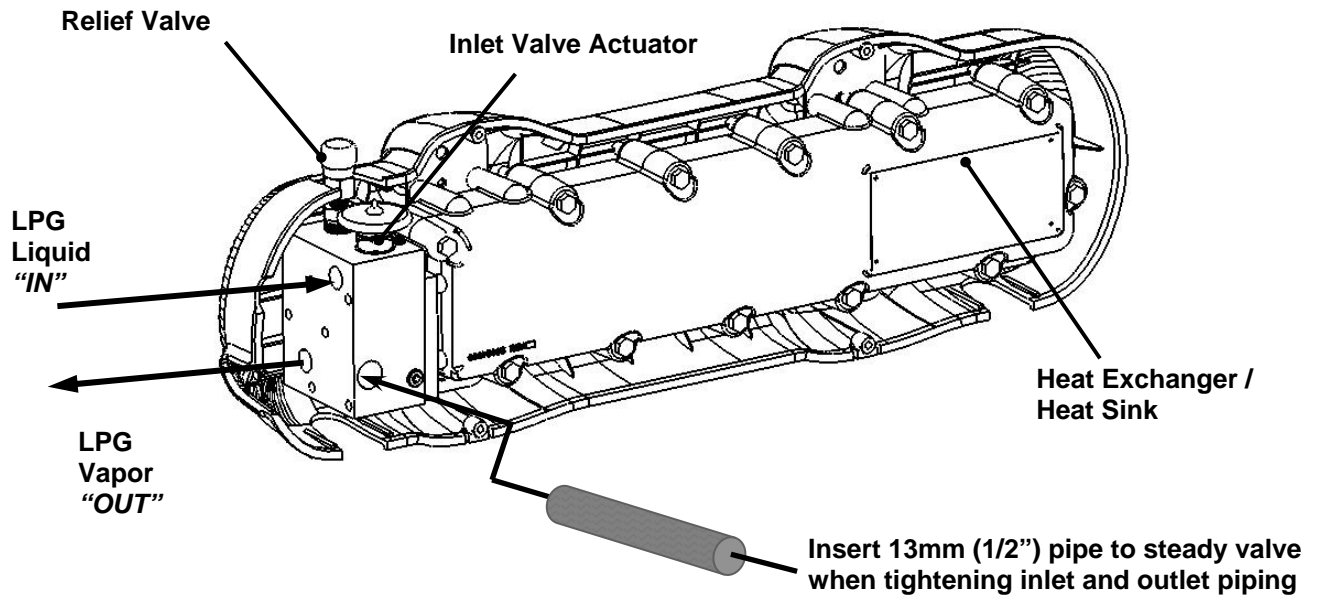

## ***Available Options***

Ask for the following items from your local **Algas-SDI** dealer:

- **Algas-SDI P/N: 80885** Wall Mount kit
- **Algas-SDI P/N: 80887** Tank Mount Kit for mounting the **ZIMMER™** to any horizontal tank up to 48" diameter.
- **Algas-SDI P/N: 80888 ( includes Kit P/N: 80890 )** Piping Kit for use with Tank Mount Kit
- **Algas-SDI P/N: 80890** Outlet regulator and gauge kit with Fluorocarbon elastomers for high temperature gas
- **Algas-SDI P/N: 80892** Strainer with 40 mesh and piping kit (See page 13)
- **Algas-SDI P/N: 20556 FILTAIRE™** - Vapor filter for filtering out heavier hydrocarbons
- **Algas-SDI P/N: 80895** Seal-Off & Junction box kit, 3/4" NPT, (USA conduit )  
Class 1, Division 1, Group D
- **Algas-SDI P/N: 80896** Seal-Off & Junction box kit, M20, without Gland, ( European )  
EEx d II A, ATEX

## **Safety**

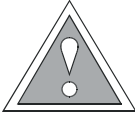

### **CAUTION**

---

*Propane Odor can fade.*

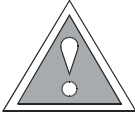

### **CAUTION**

---

*Vaporizer may be hot after or during use. Do not remove cover prior to allowing the unit to cool.*



### **CAUTION**

---

*Allow only a TRAINED and FULLY QUALIFIED PERSON to service this equipment.*

---

---

## **WARNING**



*The equipment described in this manual is designed to operate with LP-gas, a flammable fuel under pressure. The nature of the application involves inherent hazards that could result in injury. ONLY a trained and fully qualified person should service this equipment.*

---

## **NOTE**

*Prior to installing your new ZIMMER™, check all relevant codes and standards that apply in your local area to ensure compliance!*

---

## **CAUTION**

*To prevent ignition of hazardous atmospheres,*



- 1. Any repairs internal to the flameproof enclosure must be made by the manufacturer or its authorized service center.*
- 2. Keep flameproof enclosure tight, torque to 40,6 Nm ( 30 ft. lbs.) while in service, and disconnect power before installing or removing unit from service.*

---

## **NOTE**

*Installer must connect a metal stopping box immediately adjacent to the metal terminal box (connection facility). The metal terminal box is to be located outboard the metal stopping box.*

- 1. Metal Stopping Box/ Metal Conduit seal (3/4"):  
EEx d II A, ATEX certified - marking for Europe; or Class I, Division 1, Group D (UL listed or equivalent) - for US and Canada. Electrical supply wiring and seal must be rated for 120°C (248°F).*
- 2. Metal Terminal Box (3/4"):  
EEx d II A or EEx e II, ATEX certified - marking for Europe; or Class I, Division 1, Group D (UL listed or equivalent) - for US and Canada. Electrical must be rated for 120°C (248°F).*

---

## **CAUTION**



*To avoid electrostatic discharge, clean cover with a damp cloth.*

---

## Preparing the site

When preparing your site, consider local setback limitations for your desired storage container(s). Also give consideration to points of ingress/egress and other openings into buildings, including any air intakes. The **ZIMMER™** vaporizer is explosion-proof, which means that it can be mounted next to, on, or near the storage container(s).

- For portable applications the **ZIMMER™** can be mounted on the storage container. Make sure the mount touches the vessel in as small an area as possible to avoid corrosion on the vessel surface.
- For stationary applications it is best to mount the **ZIMMER™** on a wall or support near the container(s).

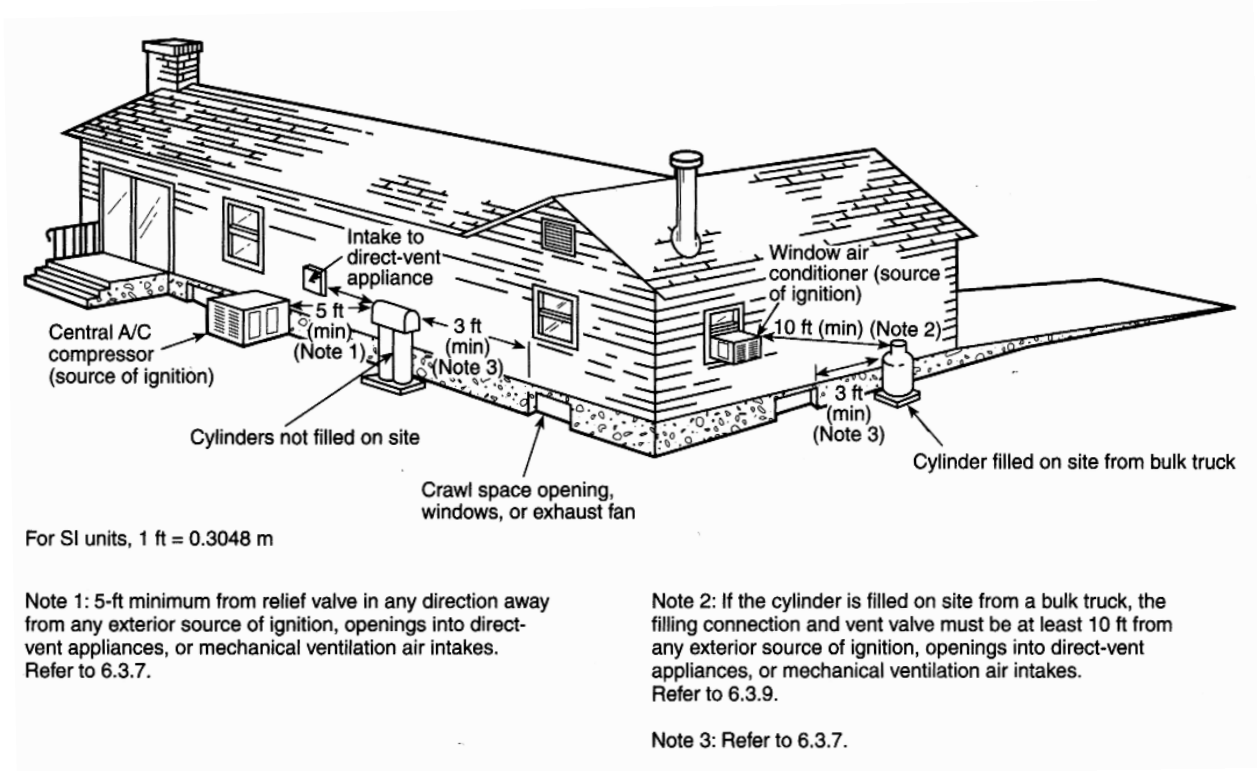

From: NFPA 58, 2004 edition, Annex I



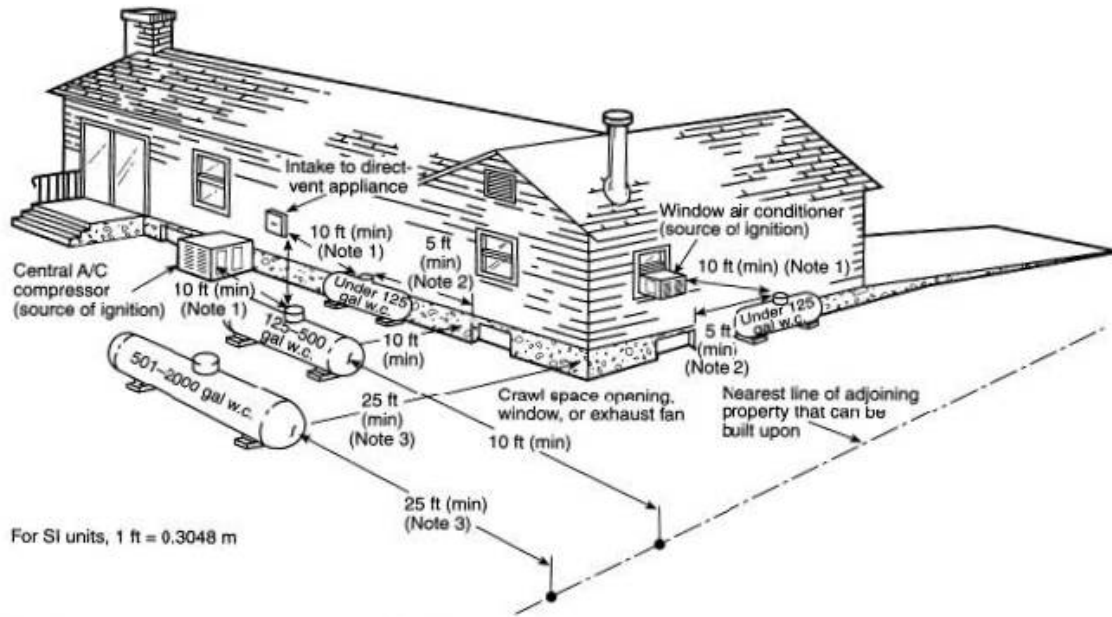

Note 1: Regardless of its size, any ASME container filled on site must be located so that the filling connection and fixed maximum liquid level gauge are at least 10 ft from any external source of ignition (e.g., open flame, window A/C, compressor), intake to direct-vented gas appliance, or intake to a mechanical ventilation system. Refer to 6.3.9.

Note 2: Refer to 6.3.9.

Note 3: This distance may be reduced to no less than 10 ft for a single container of 1200 gal (4.5 m<sup>3</sup>) water capacity or less, provided such container is at least 25 ft from any other LP-Gas container of more than 125 gal (0.5 m<sup>3</sup>) water capacity. Refer to 6.3.3.

FIGURE I.1(b) Aboveground ASME Containers. (This figure for illustrative purposes only; code shall govern.)

From: NFPA 58, 2004 edition, Annex I

## **Materials you may need for installation**

- ◆ Storage tank; or cylinder(s) with liquid withdrawal valve(s) also called “dip tube(s)”, are required.
- ◆ Excess flow valve(s)
- ◆ Manifold kit if using multiple cylinders
- ◆ ½” NPT Inlet isolation valve with hydrostatic relief valve approved for liquid LP Gas service ( included with **Algas-SDI P/N 80892** )
- ◆ Piping components including forged steel union or removable compression/flange fittings
- ◆ Schedule 80 pipe for liquid service, or approved tubing and fittings

- ◆ Inlet strainer, ½” NPT, with 40 mesh screen ( included with **Algas-SDI P/N 80892** )
- ◆ Outlet regulator, REGO model x1584MN or equivalent ( **Algas-SDI P/N 80890** ) (Outlet Range 0.21 – 2.10 Bar [3-30 psig])
- ◆ Outlet isolation valve, ½” NPT, approved for LP Gas vapor service ( included with **Algas-SDI P/N 80892** )
- ◆ Vaporizer mounting kit ( **Algas-SDI P/N 80885** )
- ◆ Electrical disconnect switch rated for 30 amps at 240VAC or 40 amps at 100VAC for Z40 and 40 amps at 240VAC or 50 amps at 100VAC for Z50
- ◆ Circuit breaker:
  - Z40: 208-240V use a UL listed 30 amp high inrush circuit breaker  
100-120V use a UL listed 40 amp high inrush circuit breaker
  - Z50: 208-240V use a UL listed 40 amp high inrush circuit breaker  
100-120V use a UL listed 50 amp high inrush circuit breaker

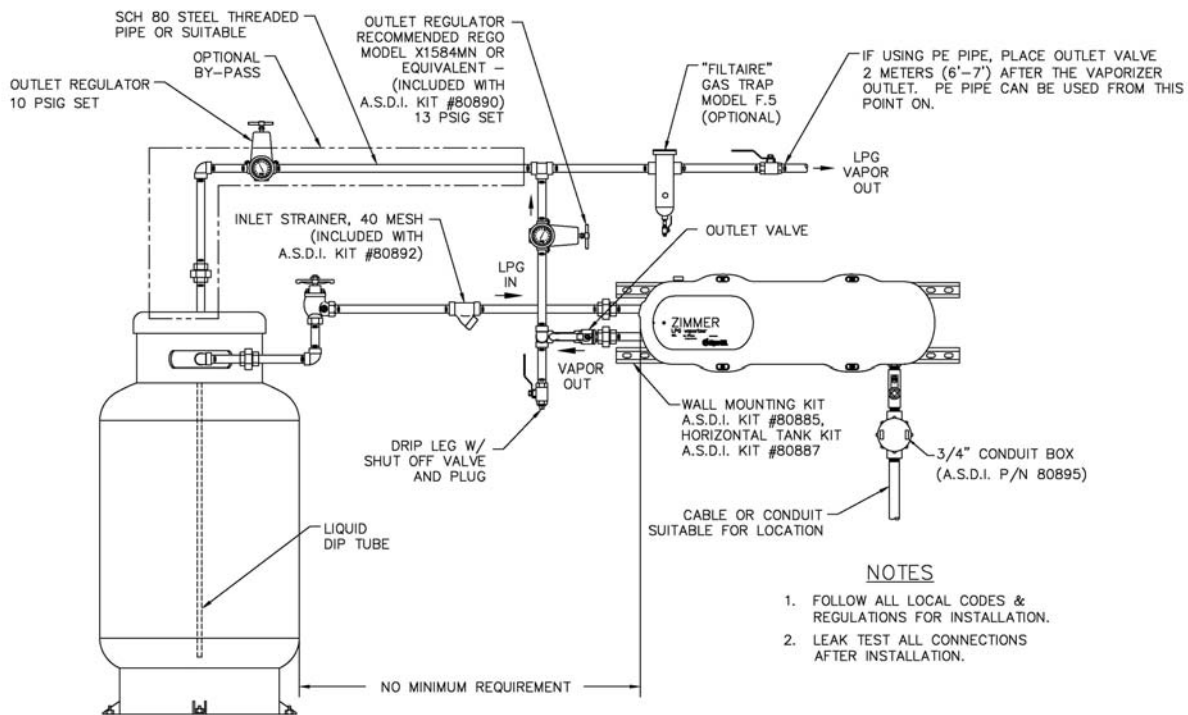

**Typical Installation with Stationary Cylinder**

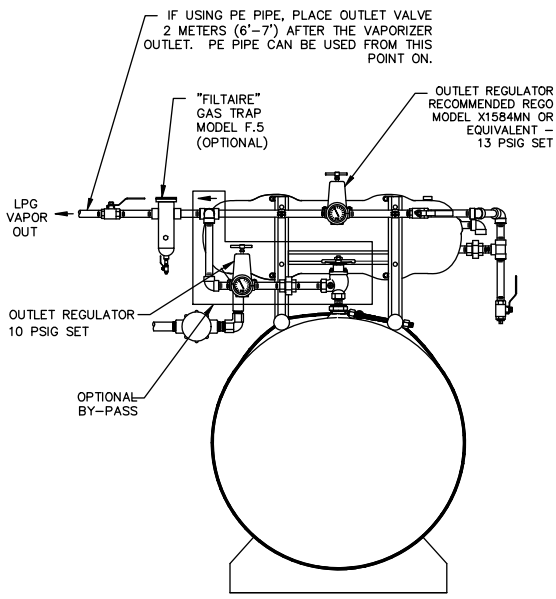
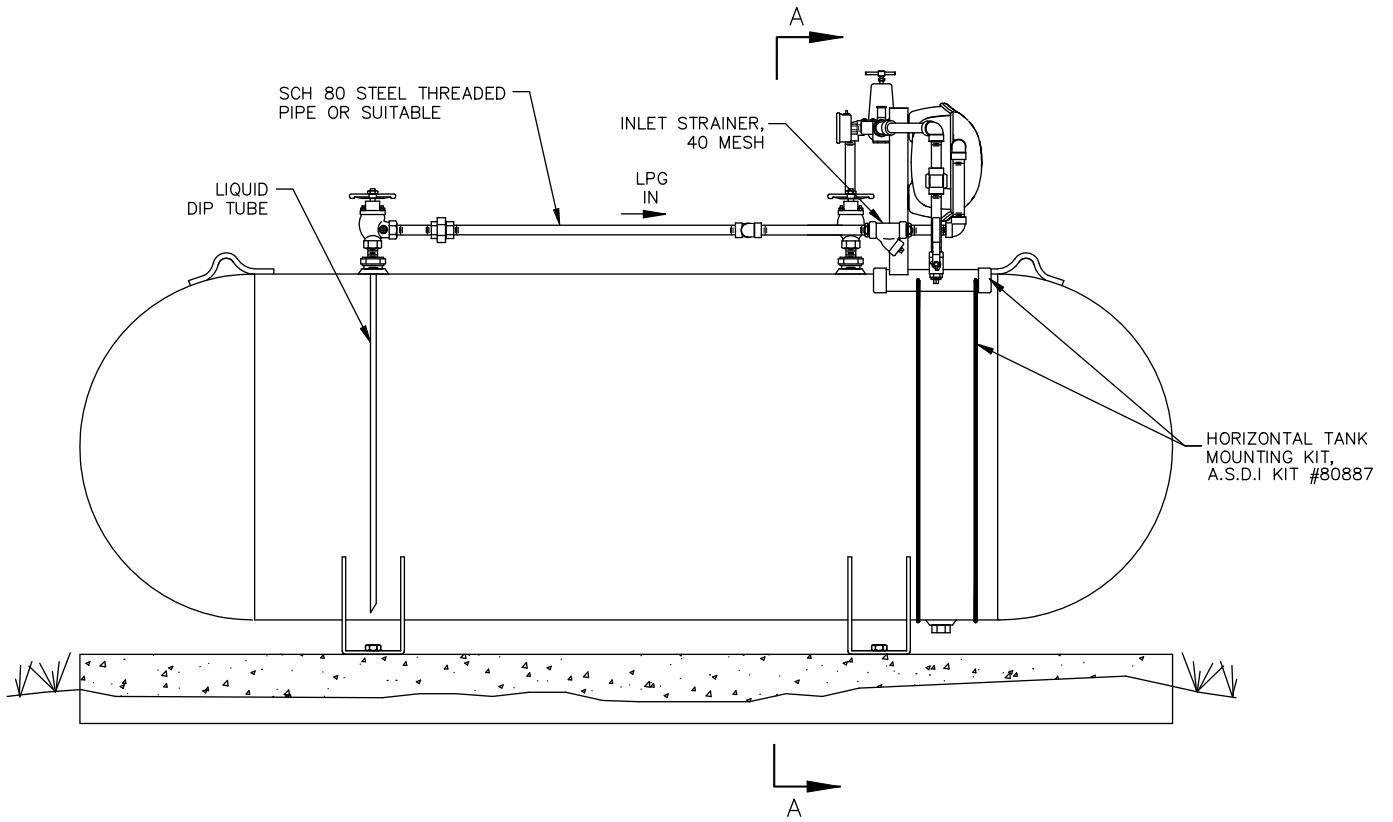

VIEW A-A

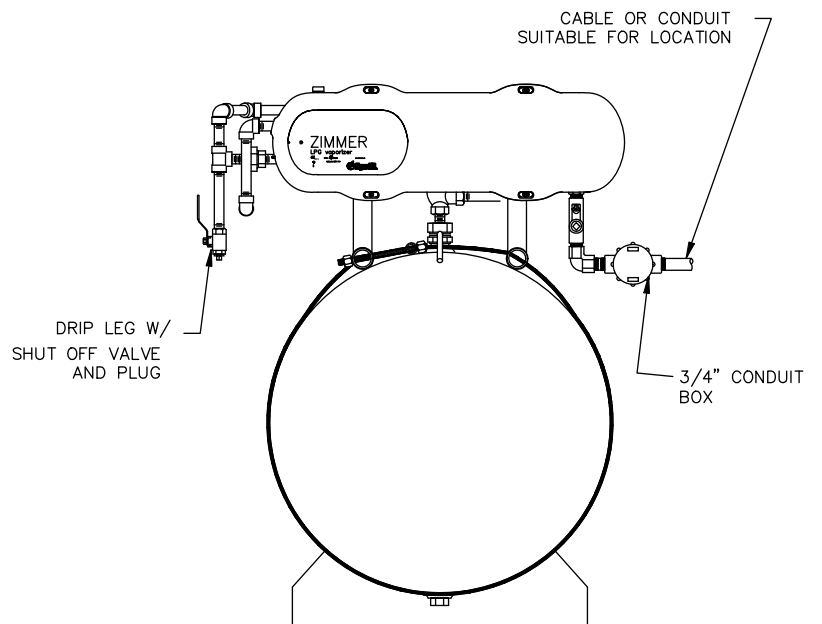

### Typical Tank Mount Installation

# Mounting the ZIMMER™

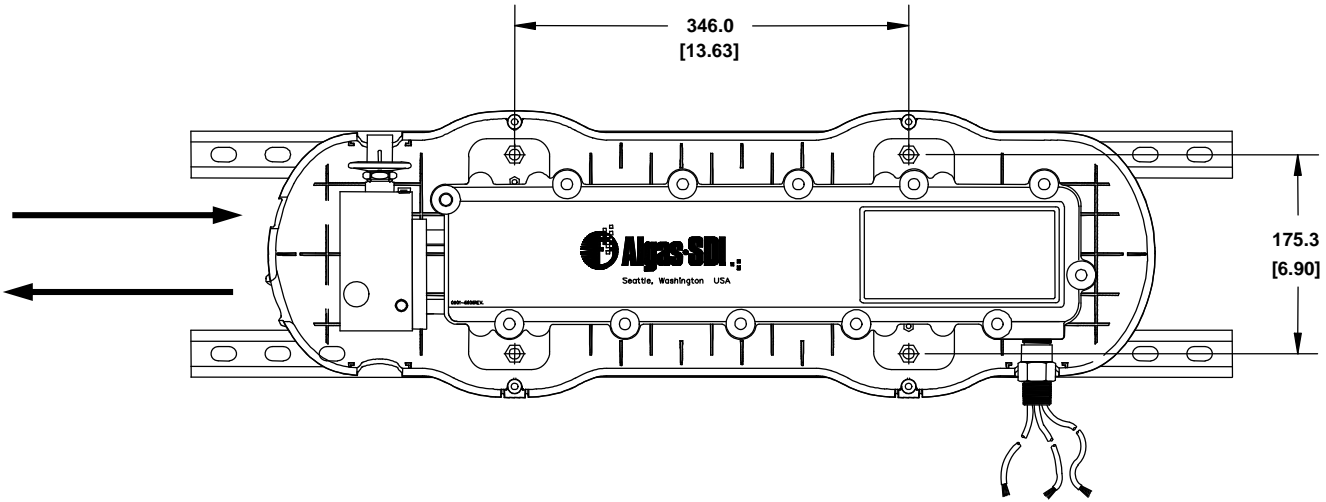

If mounted outdoors, the **ZIMMER™** must be mounted on a vertical or horizontal surface to maintain its enclosure rating. Use **Algas-SDI** Mounting Kit **P/N 80885**, or equivalent components, when mounting the **ZIMMER™** to a concrete, masonry or wood construction wall.

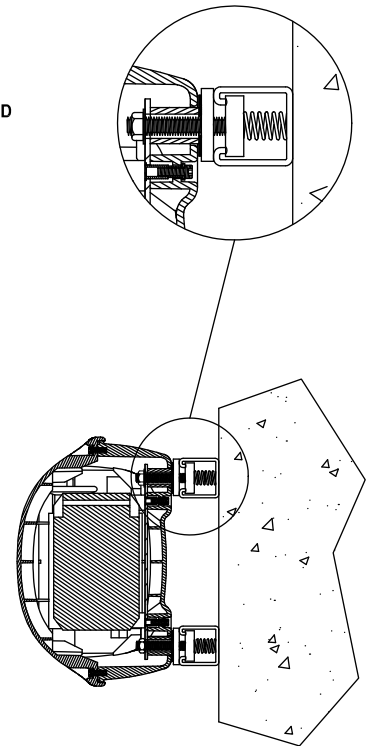
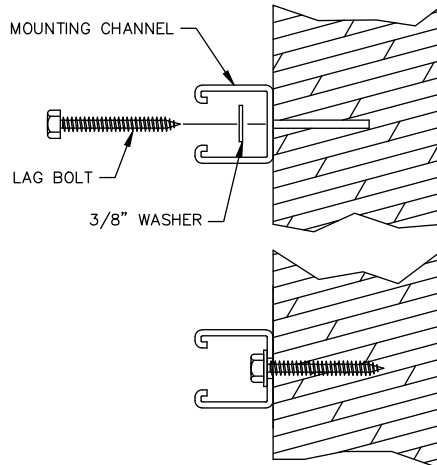
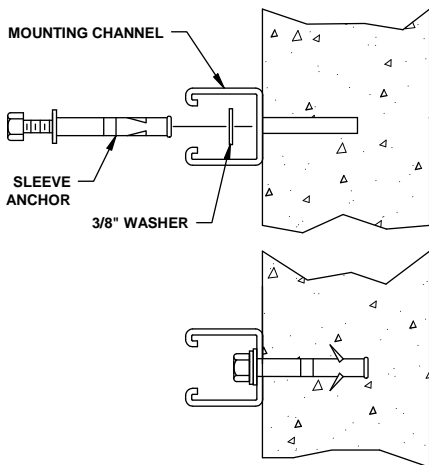
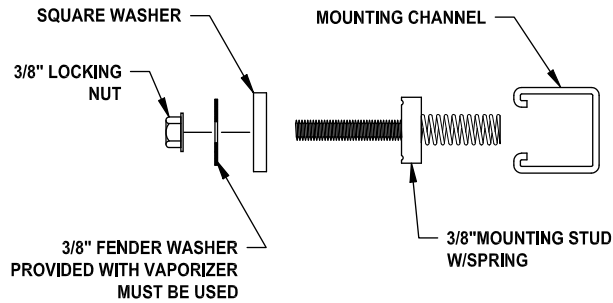

# ZIMMER™ Tank Mounting Kit Instructions

ZIMMER™ Tank Mounting Kit Instructions – Use with kit 80887 bracket assembly and 80888 piping kit (sold separately)

## 80887 Tank Mount Kit contents:

- 1 Tank Bracket
- 1 Tension bar
- 1 Tension rod 1/2" – 13 threaded
- 2 Hex nut, 1/2" – 13
- 30' Cable, 1/8" vinyl coated
- 4 Vinyl pipe cap
- 2 Top cap for bracket
- 4 Hex head bolt, 3/8" – 16 x 2-3/4" lg
- 8 Hex nut, 3/8" – 16
- 12 Flat washer, 3/8
- 4 Split washer/ 3/8



## 80888 Piping Kit contents:

- 1 Nipple, sch 80, 1/2" x 2" lg
- 2 Nipple, sch 80, 1/2" x 3" lg
- 4 Nipple, sch 80, 1/2" x 4" lg
- 4 Nipple, sch 80, 1/2" x 6" lg
- 4 Nipple, sch 80, 3/4" x 2" lg
- 4 Nipple, sch 80, 3/4" x 6" lg
- 1 Nipple, sch 80, 1/2" x 12" lg
- 2 Bushing, 3/4" x 1/2" NPT
- 1 Plug, 1/2" NPT
- 1 Tee, 1/2" NPT
- 2 Union, 1/2" NPT
- 3 Elbow, 1/2", 90 deg
- 1 Elbow, 1/2", 45 deg
- 1 Hydro Relief Valve, 1/4"
- 2 Ball Valve, 1/2" NPT, brass
- 2 Pipe Bracket, 1/2"
- 1 Press regulator, Rego X1584MN
- 1 Press Gauge, 0-30 psi, dry
- 1 Strainer, 3/4" NPT, 40 mesh
- 1 3/4" Check-Lok Adapter
- 1 Instructions, Tank Mounting Kit

This kit is intended for use with all horizontal tanks up to 48" outer diameter. Larger tanks can be accommodated by using longer 1/8" vinyl coated cable.

1. Assemble the 4 vinyl pipe caps onto each end of the bracket.
2. Install the 2 top caps onto the bracket.
3. Locate the (4) 3/8" bolts and fasten the ZIMMER™ (with cover removed) to the bracket as shown. The ZIMMER™ should be mounted to the flat side of the channel.

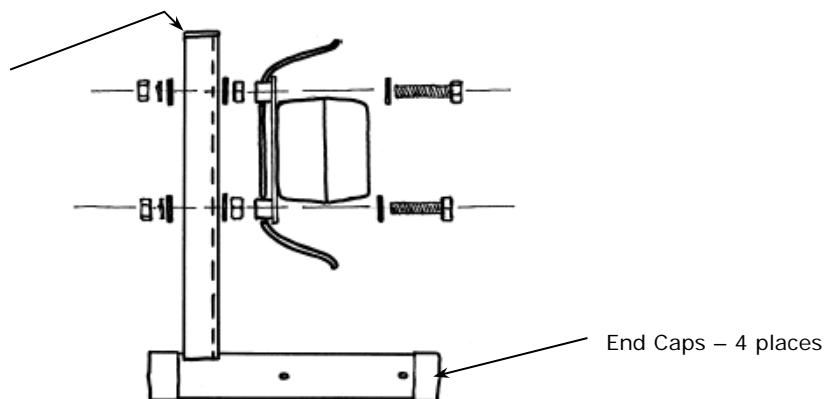

- Mount as many of the piping components to the **ZIMMER™** as possible. Install the 3/4" x 1/2" NPT reducing bushings into each end of the strainer provided. To complete the piping installation you will need to have a shutoff valve located before the **ZIMMER™**. This valve should be as close to the outlet of the tank as possible. Always install hydrostatic relief valves between any two points in the liquid piping that can trap liquid. Use schedule 80 pipe or tubing suitably rated for liquid LP-Gas service.

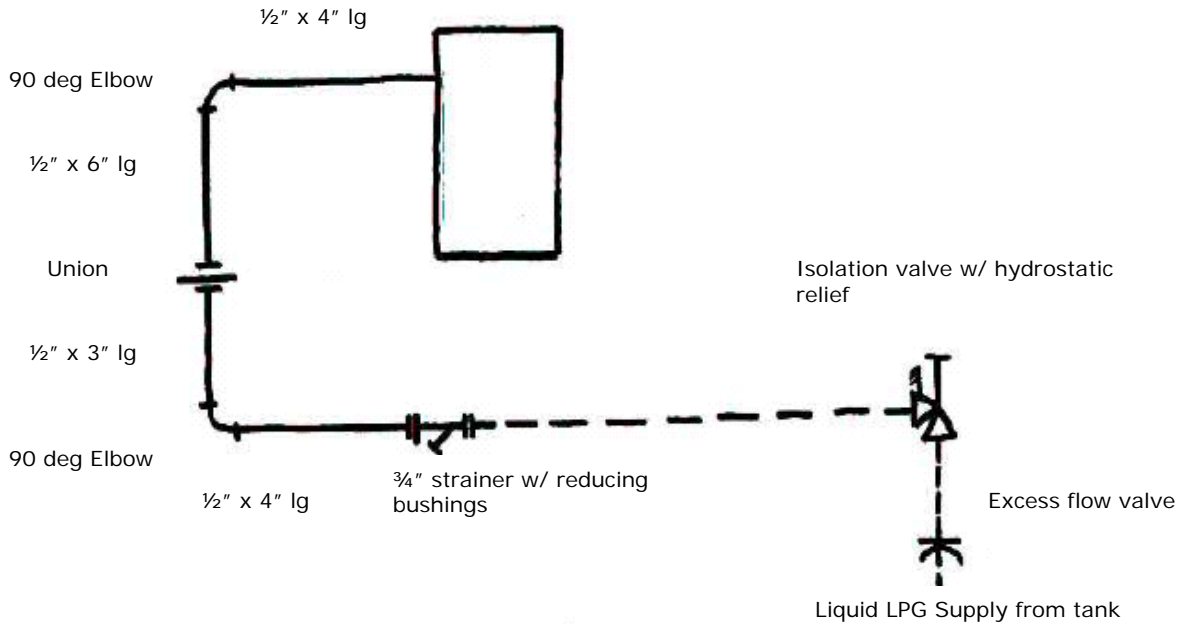

- Insert the pressure gauge in one of the 1/4" NPT openings provided on the regulator.
- Wrap the outlet piping around the backside of the **ZIMMER™** and use the pipe clamps provided to secure the piping to the open side of the channel.

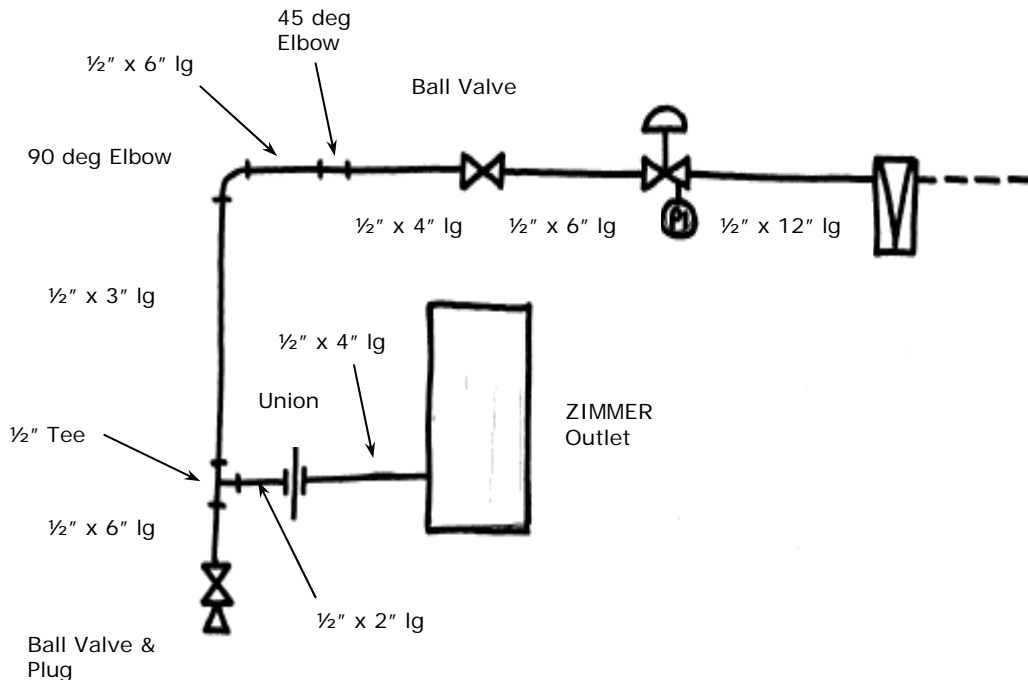

7. Paint the piping as needed and allow it to dry.
8. Survey the tank and determine the best mounting site – preferably toward one end of the tank.
9. Starting from the inside of the bracket and the side with the 9/16" diameter hole, place each end of the cable through the two 1/4" diameter holes. Feed the cable all the way through so that it is centered at each end.

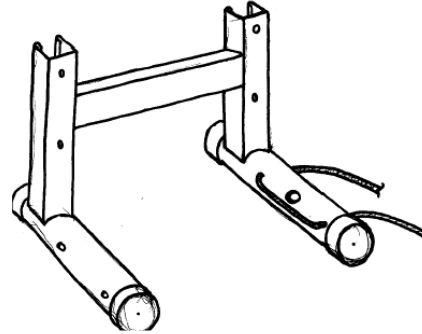

10. Place the *ZIMMER™* and bracket assembly onto the tank in the desired location.
11. Place the cable around the bottom of the tank and feed it through the two 1/4" openings on the opposite side of the bracket.

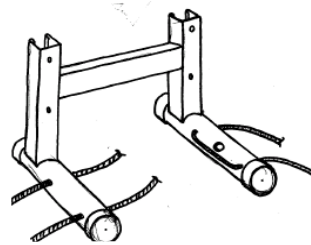

12. Insert the 1/2" –13 threaded rod through the hole in the bracket and thread on one of the 1/2" nuts.

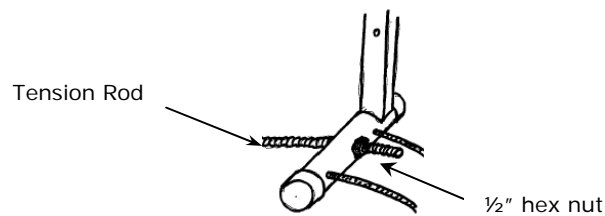

13. Place the tension bar on the other end of the 1/2" –13 threaded tension rod and thread the other 1/2" hex nut on.
14. Feed each end of the cable through the outer holes of the tension bar and pull the cable tight.

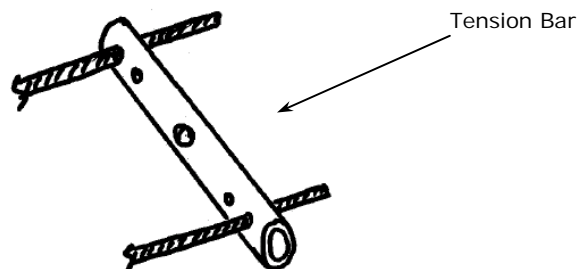

15. Feed the cable back through the inner holes. Save a small amount at the bend. Loop the cable back over the top of the tension rod and weave the cable through the small loop left at the bend. Pull the cable as tight as possible by hand.

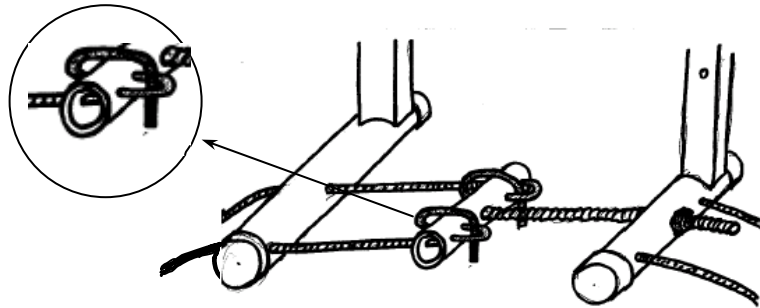

16. Tighten the ½" –13 nuts until the cables are tight and the bracket can no longer be moved on the tank.

17. Cut off any excess cable.

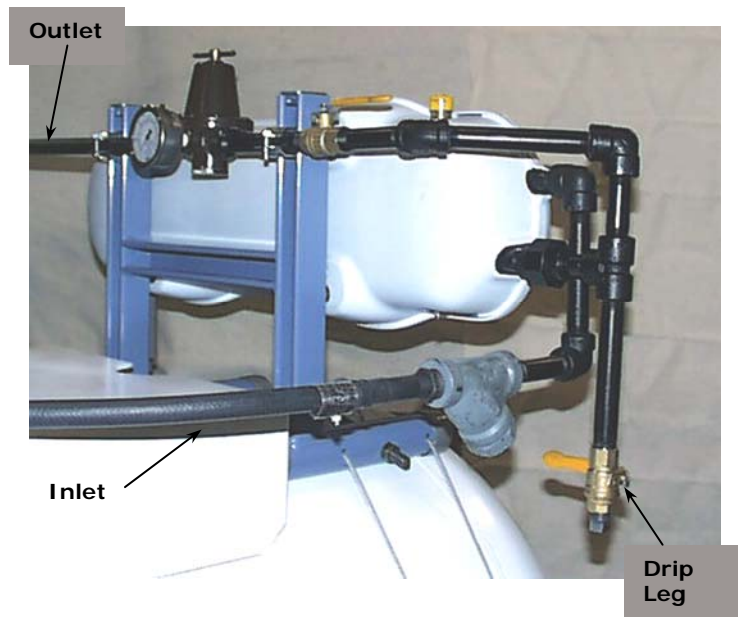

For help with questions contact your dealer or Algas-SDI at: 1.206.789.5410  
Or E-Mail: [sales@algas-sdi.com](mailto:sales@algas-sdi.com)



# Piping

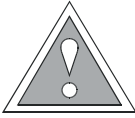

## **CAUTION**

*Teflon tape can clog orifices if not properly used. If a fitting is removed that has Teflon tape, make sure to clean all threads and remove all tape debris before re-installing.*

The **ZIMMER™** is designed for feed-through operation. If you are using cylinders to store the LPG, you will need liquid withdrawal valves in each cylinder (REGO 8556 or equivalent). It is best to use valves that have both vapor and liquid withdrawal ports – this allows you to use vapor when your load is small or when the temperature is high, and then use your vaporizer when the ambient energy is not sufficient.

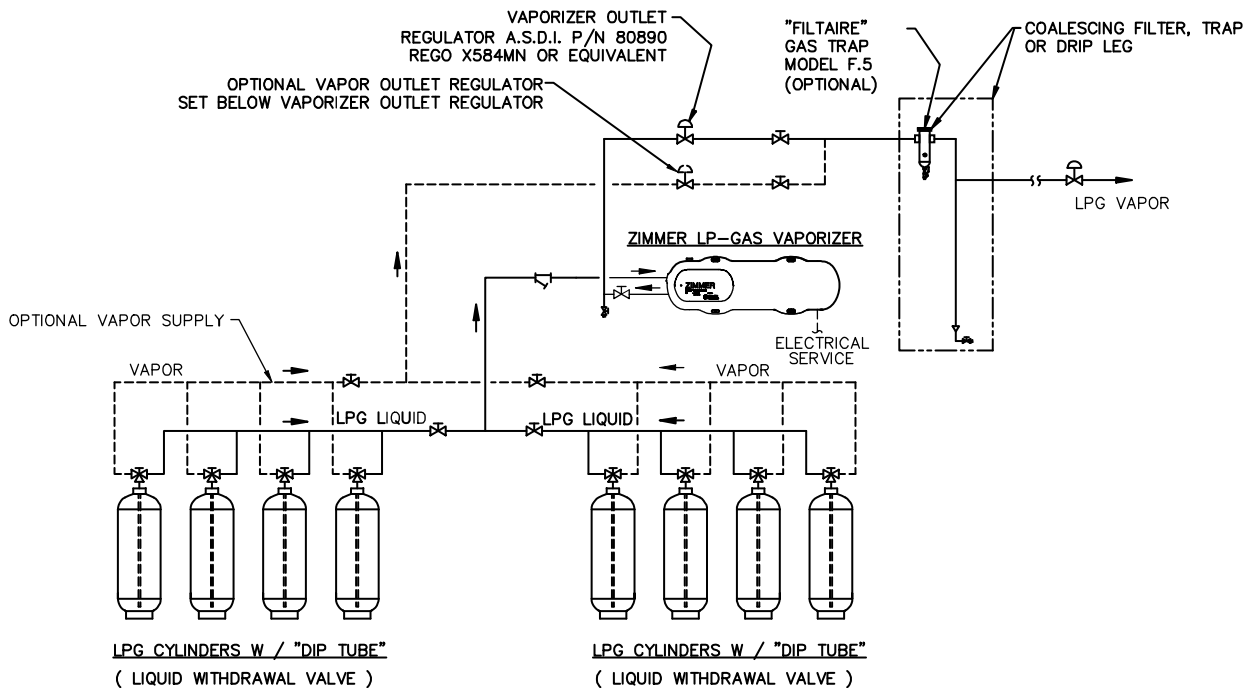

### Typical Piping Installation – Dip Tube

If you are using a tank to store the LPG, you will need to connect to the bottom of the tank or to a connection that has a "dip tube" extending into the tank for liquid withdrawal.

- ◆ Install an approved isolation valve at the outlet of the tank. If you are using cylinders you should install an isolation valve after the cylinders have been manifolded together. The isolation valve should have a hydrostatic relief valve installed to protect the pipe section between the valves.
- ◆ After the isolation valve, install a ½” or ¾” NPT strainer with a 40 mesh, or smaller, screen.
- ◆ Connect the strainer to the inlet of the **ZIMMER™** using ½” pipe, Schedule 80.

---

**NOTE**

---

*Do not install a check valve between the ZIMMER™ and the tank or cylinders! Liquid must be able to back-flow if necessary.*

---

- ◆ At the outlet of the **ZIMMER™** install an isolation valve approved for LPG vapor service.
- ◆ Next, install a pressure regulator with Fluorocarbon elastomers such as a Rego X1584MN. Install this regulator as close to the outlet of the vaporizer as possible and always at a higher elevation than the vaporizer outlet to allow any condensed liquid to travel back to the vaporizer. Never install the regulator more than 3 meters (10 feet) from the vaporizer. If you are using PE pipe after the regulator, make sure to install the regulator 2 meters (6-7 feet) after the vaporizer.
- ◆ Install a pressure gauge in the regulator or at the regulator outlet.
- ◆ After the regulator install a “drip-leg” in the piping or a vapor filter to collect any residue or heavy-ends from the LPG. The drip leg should terminate with a valve and a plug for draining.

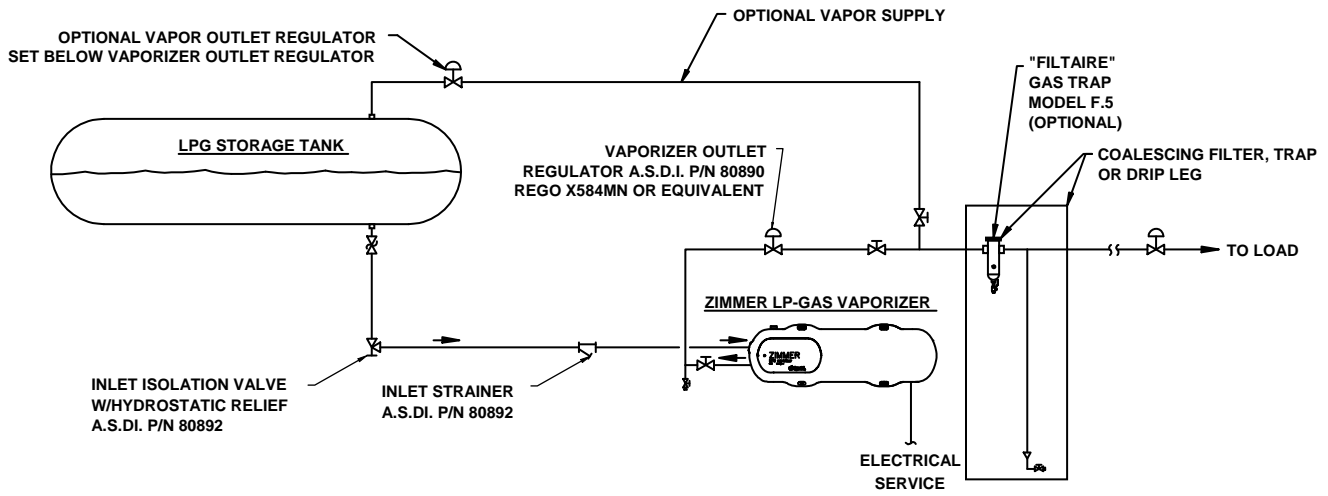

**Typical Single Tank Piping Installation – from bottom of tank**

# Installing Multiple Units

Multiple **ZIMMER™** vaporizers can be manifolded together to increase the total system capacity.

- ◆ Manifold the inlets and outlets together using similar length piping runs. It is best to keep the piping as short as possible.
- ◆ Install an isolation valve at the inlet and outlet of each vaporizer.
- ◆ Install an appropriate sized regulator with Fluorocarbon elastomers after the outlets have been manifolded together. For more than two units a Fisher 627 with a Fluorocarbon diaphragm should be used.

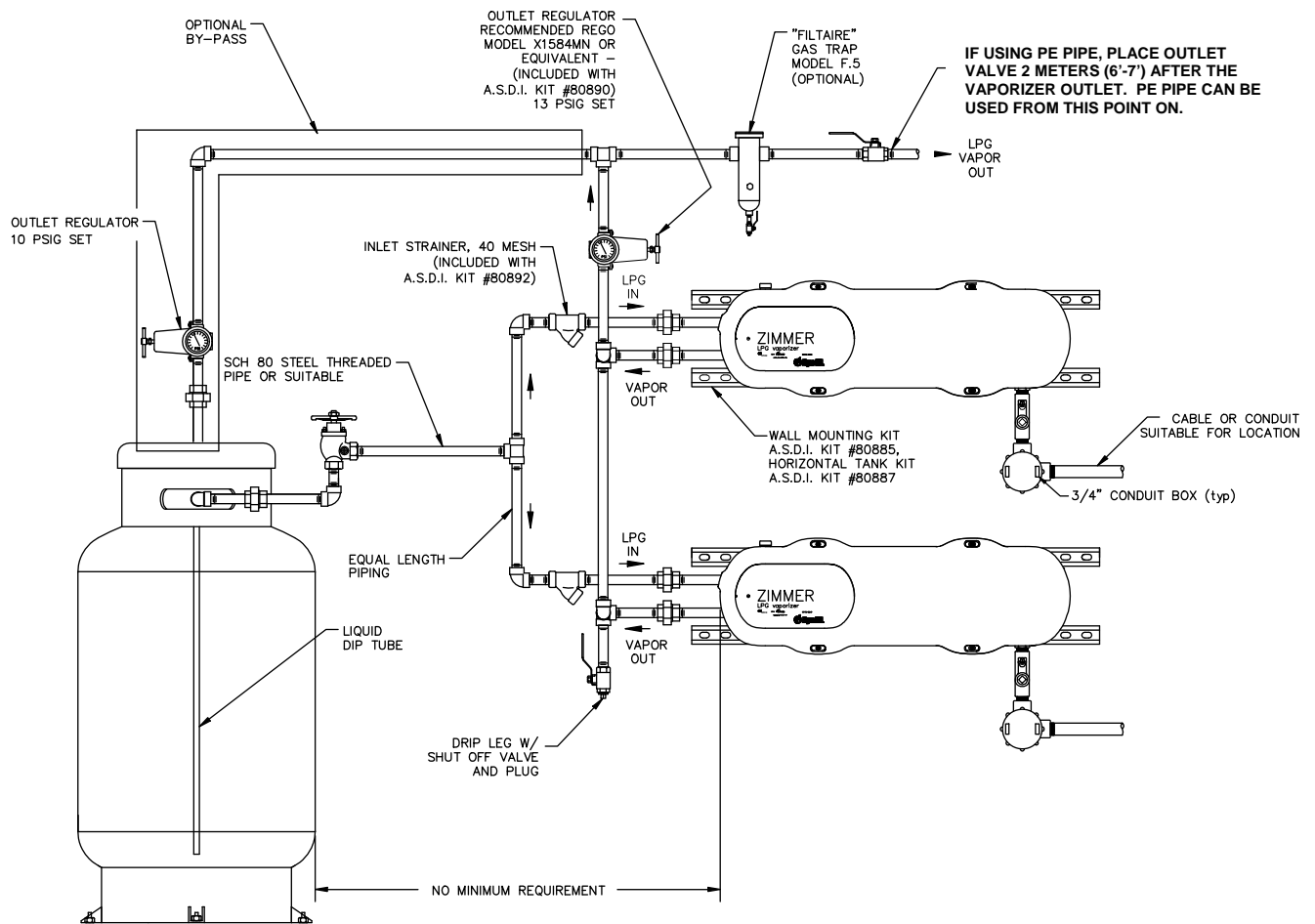

**Typical Multiple unit Installation**

## ***Common piping problems***

**Problem:** Frost or condensation on the liquid LPG piping.

**Cause:** Vaporizer installed with undersized piping from storage container to vaporizer.

**Reason:** Liquid LPG boils in the pipe before the vaporizer causing a reduction in vaporization capacity.

**Problem:** Moisture or water droplets on the piping before the regulator. Frosting of the regulator.

**Cause:** Outlet regulator installed too far from vaporizer or below vaporizer outlet.

**Reason:** High pressure LPG vapor condenses between the vaporizer outlet and the regulator.

**Problem:** Downstream component failure.

**Cause:** Drip leg or filter is not installed or is too small.

**Reason:** Oils or heavy ends collect in downstream regulators and other components.

## ***Electrical Service***

The **ZIMMER™** vaporizer is manufactured as an explosion proof device suitable for hazardous locations. Do not separate the heat exchanger castings to access the electrical enclosure – ***separating the castings will void the warranty!***

- ◆ When connecting the electrical service for the **ZIMMER™** you will need a circuit breaker or fuses appropriate for the application (refer to the materials section earlier in this chapter).
- ◆ You will also need a disconnect switch located within sight of the vaporizer.
- ◆ Select the appropriate size conductors based on the current draw and conductor run distance (refer to the Technical Specifications section at the end of this manual).
- ◆ Install a ¾" NPT metal stopping box/ metal conduit seal within 150mm (6") of vaporizer and before any other fitting.

Metal Stopping Box/ Metal Conduit seal (3/4"):

EEx d II A, ATEX certified - marking for Europe; or Class I, Division 1, Group D (UL listed or equivalent) - for US and Canada. Electrical supply wiring and seal must be rated for 120°C (248°F)

- ◆ Install a 3/4" NPT metal terminal box after the seal-off to make the wiring connections.

Metal Terminal Box (3/4"):

EEx d II A or EEx e II, ATEX certified - marking for Europe; or Class I, Division 1, Group D (UL listed or equivalent) - for US and Canada. Electrical must be rated for 120°C (248°F).

- ◆ Do not separate the heat exchanger sections to access the wiring. Use wire assembly provided.
- ◆ Connect the green/yellow wire to ground.
- ◆ After verifying all wiring, fill seal-off with sealing compound.

---

## ***WARNING***

---

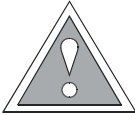

*The equipment described in this manual is designed to operate with LP-gas, a flammable fuel under pressure. The nature of the application involves inherent hazards that could result in injury. ONLY a trained and fully qualified person should service this equipment.*

---

## ***CAUTION***

---

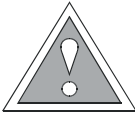

*To avoid electrostatic discharge, clean cover with a damp cloth.*

---

## ***Putting your vaporizer into service***

After completing the piping work, leak check all connections with a soap solution and pressure from the tank or from a pressure tap and compressed air bottle.

To initiate operation of the **ZIMMER™** vaporizer, engage the electrical supply at the disconnect and open all valves from the container(s) to the vaporizer.

Depending on the conditions, it could take up to 30-60 minutes for the vaporizer to be ready for full use.

Open the shut-off valve located at the outlet of the vaporizer.

Procedure for decreasing startup time:

1. Leave inlet valve closed (no pressure to vaporizer).
2. Start **ZIMMER™** and allow unit to heat up for 10-20 minutes. For cold weather conditions allow an additional 20-30 minutes to warm-up.
3. Slowly open inlet valve.
4. Inlet valve should open.

If starting the system for the first time; set the first stage regulator at the outlet of the vaporizer to 0.35 bar (5 psig) or at the desired pressure. This pressure should be kept as low as possible to reduce the risk of vapor re-liquification.

The system should now be ready for use. The vaporizer is designed to be used continuously or can also be used for just the amount of time necessary.

---

***NOTE***

*During the first few days of use it is a good idea to blow-down the drip leg and strainer to remove any debris that may be left over from installation.*

---

## ***Shutting down the system***

For overnight or short time periods:

- ◆ Because the vaporizer uses only a very small amount of electricity (approximately 300-600 watts) when there is no load, it is suitable to leave the power engaged even during periods of non-use. If desired, close the vaporizer outlet shut-off valve when the vaporizer is not being used.

For extended periods:

- ◆ Close the vaporizer outlet shut-off valve.
- ◆ Open the disconnect switch to remove power from the vaporizer.
- ◆ Close the inlet valve or tank valve(s) only after the vaporizer has expanded the remaining gas and pushed it back toward the tank. Trapped liquid can expand when heated causing damage or possible rupture to piping and components. Always install hydrostatic relief valves between isolation valves.



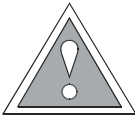

## ***CAUTION***

---

*To prevent ignition of hazardous atmospheres,*

- 1. Any repairs internal to the flameproof enclosure must be made by the manufacturer.*
  - 2. Keep flameproof enclosure tight, torque to 40,6 Nm ( 30 ft. lbs.) while in service, and disconnect power before installing or removing unit from service.*
- 

## ***Servicing your ZIMMER™***

**ZIMMER™** vaporizers are designed to need very little maintenance. The amount and frequency of maintenance will depend on the quality of the LPG. The main servicing points for the system will be the drip leg or heavy ends trap, the inlet strainer and the inlet valve screen.

### **Drip Leg and Filter**

Blow down the inlet strainer and the filter or drip leg each time the LPG tank is refilled (or each time the cylinders are exchanged). Adjust this frequency as required.

### **Inlet Valve (Cleaning Instructions)**

1. Remove the inlet valve assembly from the heat exchanger assembly by unscrewing the six M6 bolts on the end of the unit.
2. Unscrew the temperature sensing bulb, and gently slide it out of the valve to minimize capillary bending.
3. Gently unscrew and remove the actuator assembly. (**Note:** It is extremely important to prevent capillary bending.)
4. Inspect the bulb for pitting or corrosion. Replace if necessary. (Z40L P/N 40425 and Z40P P/N 40424)
5. Unscrew the valve seat assembly and remove the parts enclosed (shaft, ball, ball seat, spring, and spacers). Some of the parts, including the stainless ball, are magnetic, for ease of removal. (**Note:** Make note of the exact order that the previously mentioned parts are stacked in the unit. This includes counting the number and orientation of the spacers.)

6. Inspect the valve seat and ball. If the seating surface is smooth and does not show pitting, wipe clean and re-install. If the seat or ball is pitted, replace with a new assembly (usually once a year). Adjust frequency as required.
7. Clean the shaft, spring, spacers and valve seat assembly opening with a solvent.
8. Put the assembly back into the opening in the original order (noted in step 4). Make sure that the rounded (smooth) side of the ball seat (washer that the ball rests on) is facing the ball.
9. Install new "O" rings (2) if needed (P/N 33906 and P/N 33904)
10. Brush the threads of the valve seat assembly and "O" rings with lithium grease. Screw in the valve seat assembly (torque setting: 28-35 ft-lbs or 38-47 N-m).
11. Brush the threads of the actuator assembly with lithium grease. Screw in the actuator assembly without bending the capillary (torque setting: 25-30 ft-lbs or 34-40 N-m). (**Note:** There is no elastomer/"O" ring in this joint, it is a metal to metal connection)
12. Brush the threads of the temperature sensing bulb with lithium grease. Screw in the temperature sensing bulb.
13. Check the inlet screen to make sure it is not clogged with debris. Clean with a solvent or replace as necessary (screen P/N 0901-5017 and retainer P/N 60310). (Note: Once the screen is removed, it must be replaced with a new part) If the proper strainer is installed upstream, this screen should not become contaminated.
14. Unscrew the brass plug from the "high pressure bypass valve" (located adjacent to and under the actuator).
15. Remove the spring, check valve and "O" ring and clean with a solvent. Also clean inside the opening.
16. Place the "O" ring, check valve and spring back into the opening (See "Inlet Valve Detail" diagram for the order).
17. Brush the threads of the brass plug with appropriate thread sealant. Screw in the brass plug back into the valve body.
18. Replace the four "O" rings between the heat exchanger and valve assembly joint (P/N 33905) and re-attach the inlet valve to the main **ZIMMER™** assembly.
19. Conduct a pressure leak test on the unit.

## Heating System

Perform the following test to ensure the Z40 heaters are functioning properly:

1. Let unit cool for 5-6 hours.
2. Attach an ammeter to one leg of the power (black wire).
3. Apply power and record amperage after 20 seconds.

Results:

- 110 VAC current > 32.5 amps
- 208 VAC current > 20.5 amps
- 220 VAC current > 19.5 amps
- 230 VAC current > 18.5 amps
- 240 VAC current > 17.5 amps

## Relief Valve

Always make certain the safety pressure relief valve cover remains in place. This cover prevents water and foreign materials from collecting in the opening that may inhibit its pressure relieving ability. If this cover has come off the relief valve it usually indicates that the relief valve has opened. Before replacing this cover, leak test the relief valve by applying a soap-water solution to the top portion of the valve.

Pressure relief valves have a tendency to leak after they have opened. Additionally, some local regulations require periodic replacement of pressure safety relief valves. If you have reason to believe that this device has opened or is leaking, it should be replaced.



### ***CAUTION - HOT!***

***When removing the vaporizer cover always make sure the vaporizer has cooled prior to touching!***

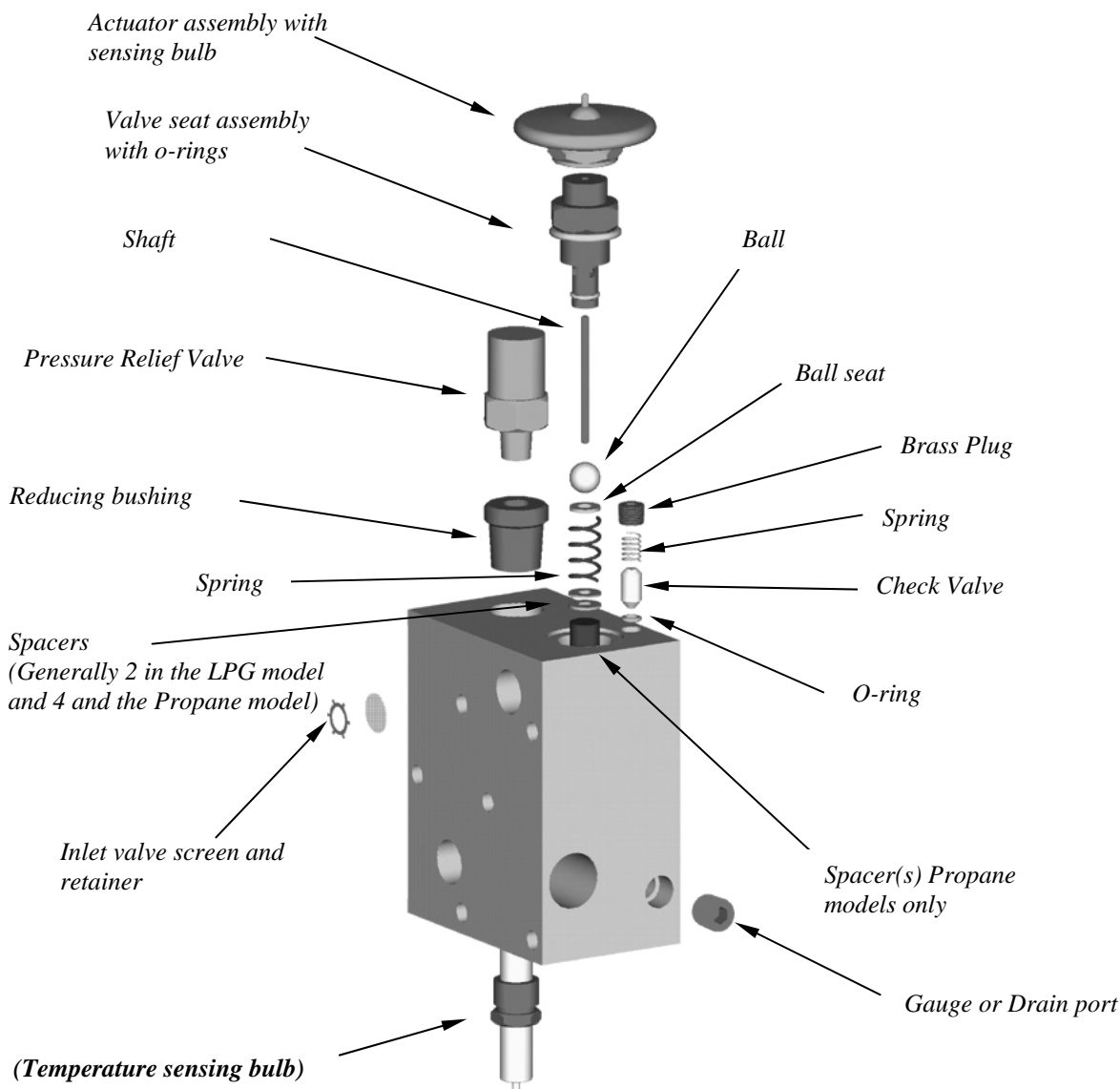

***Inlet Valve Detail***

The **ZIMMER™** is a very simple device with few areas for problems to occur. The main areas of the vaporizer are the inlet valve and the heat exchanger. The heaters used are not ordinary resistance heating elements. The heaters do not have wire filaments that are susceptible to burn-out.

## Possible problems

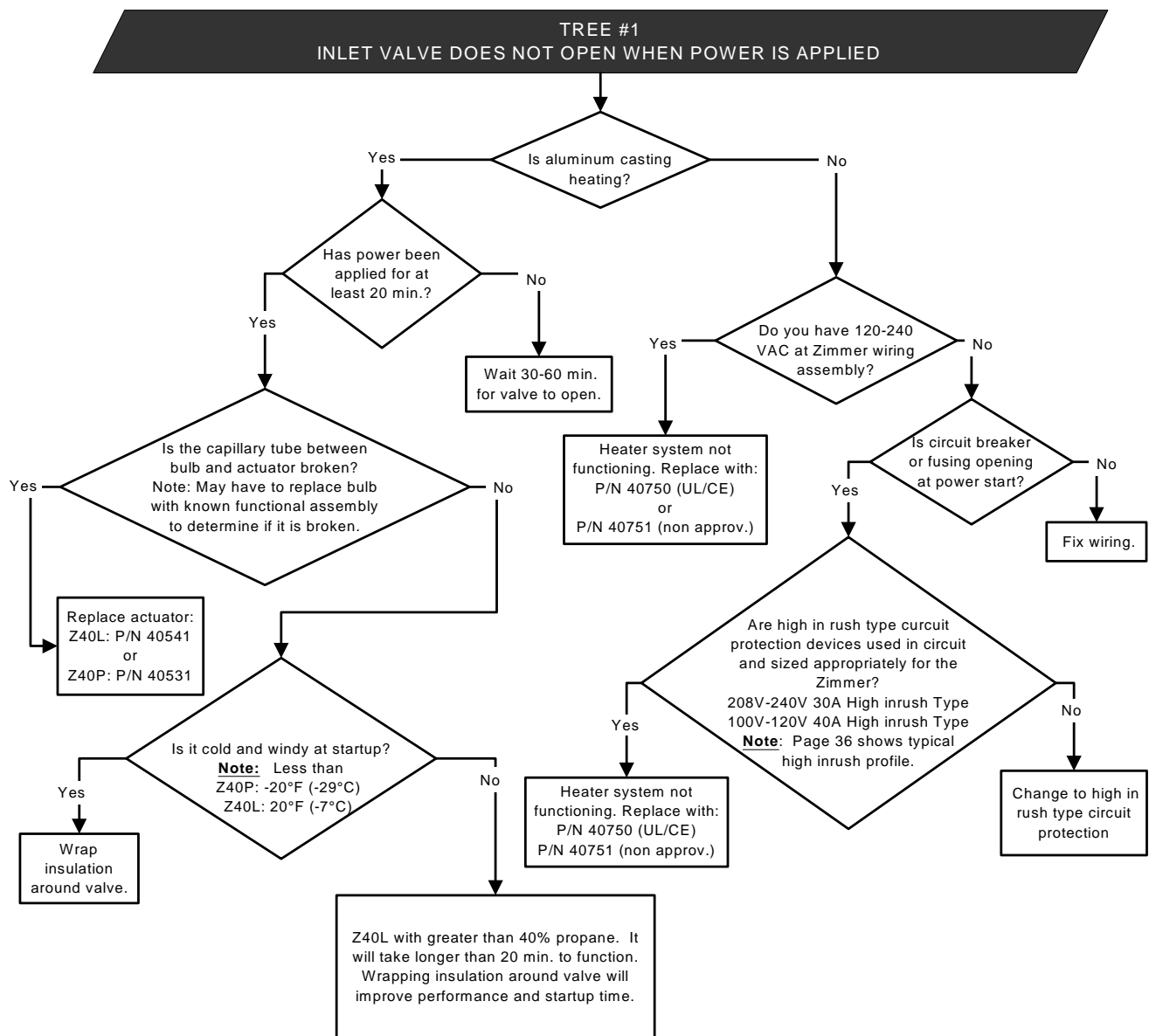

**TREE #2**  
**INLET VALVE CLOSES DURING OPERATION**

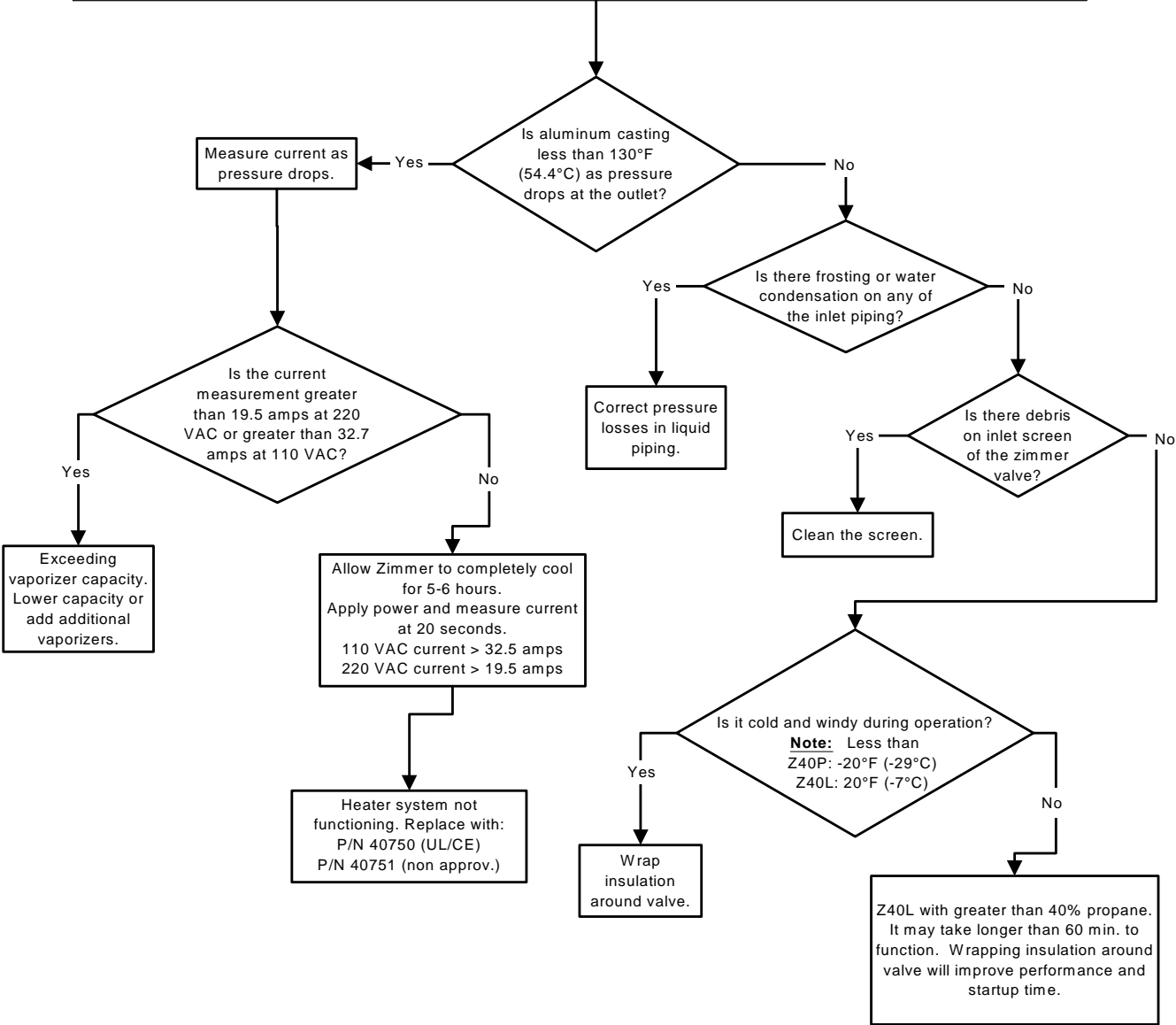

# REPLACEMENT PARTS

# 6

Item	Description	ASDI P/N			Recommended replacement interval
		50/50	70/30	PROPANE	
1	Heater Assembly - 7 heaters, spacer, buss plate and insulation pad	40560	40560	40560	N/A
1	Heater Assembly - 14 heaters, spacer, buss plate and insulation pad	40565	40565	40565	N/A
2	Inlet valve rebuild kit (LPG) - spring, seat, ball, o-rings		40540		2 years
3	Inlet valve actuator assembly (LPG) - actuator, gland nut, o-ring		40541		3 years
4	Replacement valve (LPG), complete, (includes O-Ring)		40545		N/A
2	Inlet valve rebuild kit (Propane) - spring, seat, ball, O-Rings			40530	2 years
3	Inlet valve actuator assembly (Propane) - actuator, gland nut, o-ring			40531	3 years
4	Replacement valve (Propane), complete, (includes O-Ring)			40535	N/A
2	Inlet valve rebuild kit (50/50 LPG) - spring, seat, ball, O-Rings	40530			2 years
3	Inlet valve actuator assembly (50/50 LPG) - actuator, gland nut, o-ring	40561			3 years
4	Replacement valve (50/50 LPG), complete, (includes O-Ring)	41052			N/A
5	Replacement shell - top and bottom, fasteners	40550	40550	40550	only required if damaged
6	Relief valve	33909	33909	33909	After valve opens or as required by local codes
7	O-ring ZIMMER™ Valve 0.070"w x 3/4" ID	33905	33905	33905	N/A
8	Screw, ZIMMER™ Cover Assembly	61053	61053	61053	N/A
9	Washer for ZIMMER™ Cover use with p/n: 61053	61048	61048	61048	N/A
10	Heat Exchanger Field Replacement Assy.	40751	40751	40751	N/A
10	Heat Exchanger Field Replacement Assy. UL/CE	40750	40750	40750	N/A

**Q1: What voltages can the ZIMMER™ operate on?**

**A1:** The UL/CE listing is valid for any voltage between 100 – 240VAC. (1 phase only)

**Q2: Does the ZIMMER™ obtain the same maximum capacity regardless of the supply voltage?**

**A2:** No. The 40kg/hr (20 gal/hr) rating is based on 220VAC. The capacity is reduced to 30kg/hr (15 gal/hr) when operated on 110V.

**Q3: What is the capacity rating based on?**

**A3:** The capacity is based on using a 220V power supply and with LPG having a maximum butane percentage as stated per model (Z40P or Z40L) at a temperature of 104F (40 C) and no pump.

**Q4: Can the ZIMMER™ use any mixture of propane and or butane?**

**A4:** There are two versions of the ZIMMER™ - one for commercial propane (Z40P), and one for standard LPG, 70% Butane/ 30% Propane (Z40L). The ZIMMER™ is not designed for use with commercial butanes. The Z40P is designed to operate with a maximum of 15% butane; the Z40L is designed to operate with a maximum of 80% Butane and ideally with 60-80% Butane. Using less than 60% Butane in the Z40L will result in reduced capacity. Specific vapor pressure curves are available upon request.

**Q5: What is the operating temperature?**

**A5:** The ZIMMER™ uses self-regulating heaters that are not fixed resistance. This means that the ZIMMER™ does not have a fixed temperature setting. The ZIMMER™ will reach its peak temperature at idle, at which point it will consume the least amount of energy. As the flow rate increases, heat is drawn from the heaters causing the resistance to decrease and allowing them to produce more energy.

**Q6: What is the pressure drop at maximum flow?**

**A6:** This depends on the pressure. At 100 psig (7kg/cm<sup>2</sup>) the pressure drop is less than 1 psig (0.07 kg/cm<sup>2</sup>).

**Q7: What prevents liquid from passing downstream?**

**A7:** The vapor temperature at the exit of the vaporizer in combination with the pressure exerts a specific force against a preset spring and ball assembly. As the temperature drops the resulting decrease in force on the spring causes the ball to modulate closed against the valve seat. The temperature and pressure curves are matched to commercial propane and high butane content LPG.

**Q8: Can liquid pass downstream when the electricity fails?**

**A8:** No. Because the inlet control valve does not require electricity to operate, it is failsafe. The valve operates as stated in A7 to ensure that no liquid passes downstream.

**Q9: Because there are no switches, what prevents the heaters from overheating?**

**A9:** The ZIMMER™ heaters are not traditional filament-type resistance heaters. Instead, the heaters are made from a special ceramic-like silicon material that cannot exceed a certain temperature. If the heaters are subjected to a higher temperature during use the molecular structure will degrade into an infinite resistance form yielding no heat output.

**Q10: Can I leave my ZIMMER™ on overnight while it is not in use?**

**A10:** Yes. Your ZIMMER™ was designed for continuous use. Additionally, the ZIMMER™ will consume very little energy while it is not in use (typically 300-600 watts).



**Q11: If the power goes out for a brief period of time, will it shut down the gas supply to my burners or pilots?**

**A11:** Generally, no. For short power outages the *ZIMMER™* will continue operating – even without power. Although no additional heat will be added, the heat sink generally will have enough reserve energy to sustain a short power outage. When the power comes back on the heat-sink will be replenished. Since the inlet control valve does not require electricity for operation, its function is independent of the power supply.

**Q12: Does the *ZIMMER™* have to be horizontally mounted on a wall?**

**A12:** If the *ZIMMER™* is mounted outdoors it should be mounted horizontally on a wall or structural support.

**Q13: What is the recommended first stage regulator?**

**A13:** Fisher 627-417/V1 or Rego X1584MN.

**Q14: Can the *ZIMMER™* be used in an economy configuration like the XP vaporizers?**

**A14:** It is possible, but at present *Algas-SDI* does not offer an economy kit for the *ZIMMER™*.

**Q15: How many Watts does the *ZIMMER™* use when it is at idle?**

**A15:** About 300-600 Watts – similar to 2 residential light bulbs.

**Q16: What is the minimum temperature rating for the *ZIMMER™*?**

**A16:** The UL/CE approval is valid for –20 degrees F.

**Q17: Does the capacity need to be de-rated at the minimum temperature?**

**A17:** No. In fact the *ZIMMER™* will actually vaporize more at lower temperatures.

**Q18: What is the "maximum current draw"\* from the *ZIMMER™* and under what conditions does this occur?**

**A18:** The maximum current will occur at the maximum capacity, lowest temperature and lowest voltage. The maximum power output will occur at the same conditions, except at the highest voltage.

22.1A @ 240V (-20 F)

25.5A @ 208V (-20 F)

33.3A @ 120V (-20 F)

21.6A @ 220V (40 F)

\* Maximum current draw is defined as anything after the first five seconds preceding a cold start.

# ZIMMER™ CURRENT AND POWER CHARTS

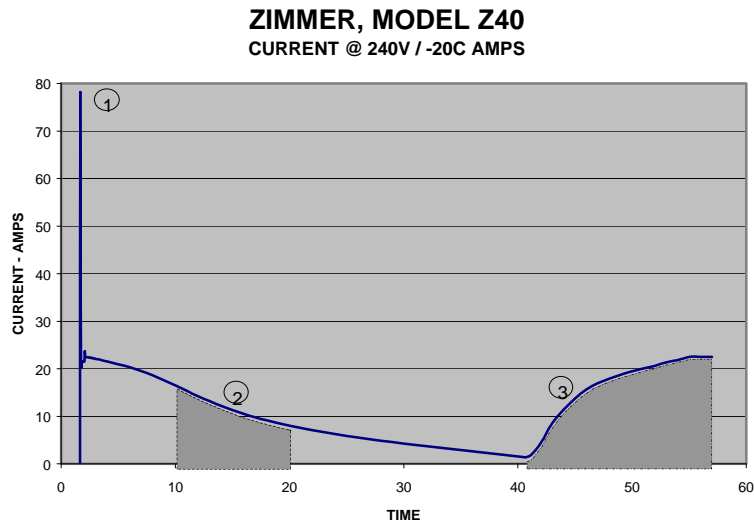
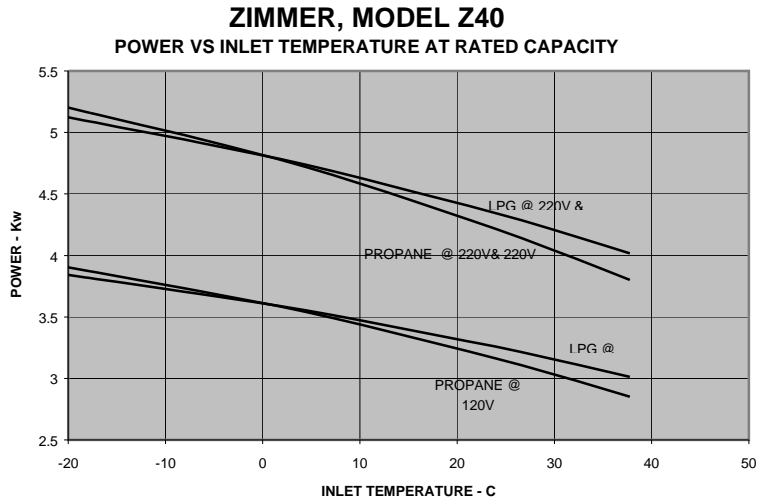

**Event 1:** Power turned on with no flow through vaporizer.

**Event 2:** Inlet valve opens and vaporizer is ready for service. Typically 10 to 20 minutes if using the fast start procedure (see procedure on page 27).

**Event 3:** 40 kg/hr flow demand is established through vaporizer.

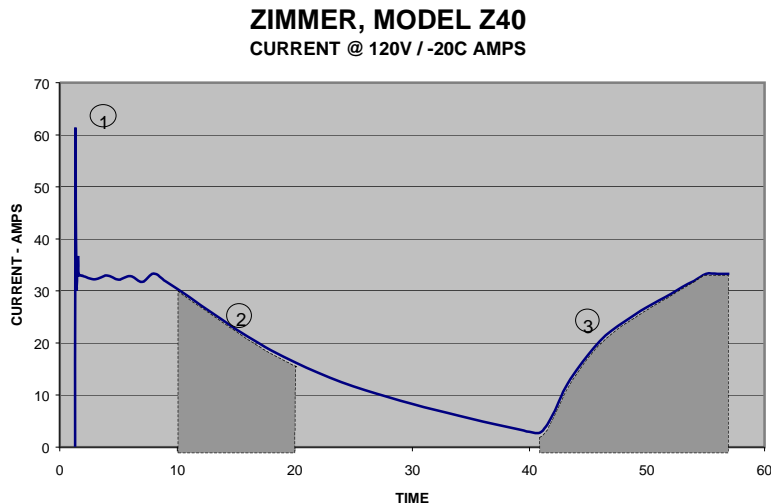

**Event 1:** Power turned on with no flow through vaporizer.

**Event 2:** Inlet valve opens and vaporizer is ready for service. Typically 10 to 20 minutes if using the fast start procedure (see procedure on page 27).

**Event 3:** 40 kg/hr flow demand is established through vaporizer.



Innovative Liquid Vaporizing and Gas Mixing Solutions

### WARRANTY REGISTRATION

Type of Equipment: \_\_\_\_\_ Serial Number: \_\_\_\_\_  
 ASDI Sales Order #: \_\_\_\_\_ Order Date: \_\_\_\_\_  
 Purchased By: \_\_\_\_\_  
 \_\_\_\_\_  
 \_\_\_\_\_

To help us give you better service, please fill out this warranty registration form and return it to ASDI to register your purchase and for follow up on the performance of ASDI equipment. We are dedicated to producing a quality product and if a problem occurs, ASDI wants to know about it.

Please help us with a small amount of information about your company and how the equipment will be used. When contacting ASDI, please have the type of equipment and the serial number handy so we can give you accurate information. If you have had any kind of problem with this equipment, or you have any comments, please attach a separate sheet to this form. Keep a copy for your records.

End Customer/Company Name: \_\_\_\_\_  
 Address: \_\_\_\_\_ Tel: \_\_\_\_\_  
 City: \_\_\_\_\_ Fax: \_\_\_\_\_  
 State: \_\_\_\_\_ Zip: \_\_\_\_\_

Name of individual to contact for follow up information: \_\_\_\_\_  
 Title: \_\_\_\_\_

Usage - Circle one:    Base Load    Standby System    Peak Shaving  
 Other: \_\_\_\_\_

In what application is the equipment being used? \_\_\_\_\_

When was the equipment put in service?    /    /  
 \_\_\_\_\_

Note:    If you have more than one piece of ASDI equipment, fill out one warranty sheet and staple the others to it, ASDI will do the rest.

151 South Michigan Street,                      Tel: 206.789.5410    E-mail: sales@algas-sdi.com  
 Seattle, Washington, 98108, USA              Fax: 206.789.5414    Internet: www.algas-sdi.com





---

**Algas-SDI International, LLC**  
**151 S. Michigan Street**  
**Seattle, Washington 98108**  
**USA**

**Ph.: 1.206.789.5410**  
**Fax.: 1.206.789.5414**

**[www.algas-sdi.com](http://www.algas-sdi.com)**

